

---

**JBL**<sup>®</sup>  
**GTO5355**  
**OWNER'S MANUAL**

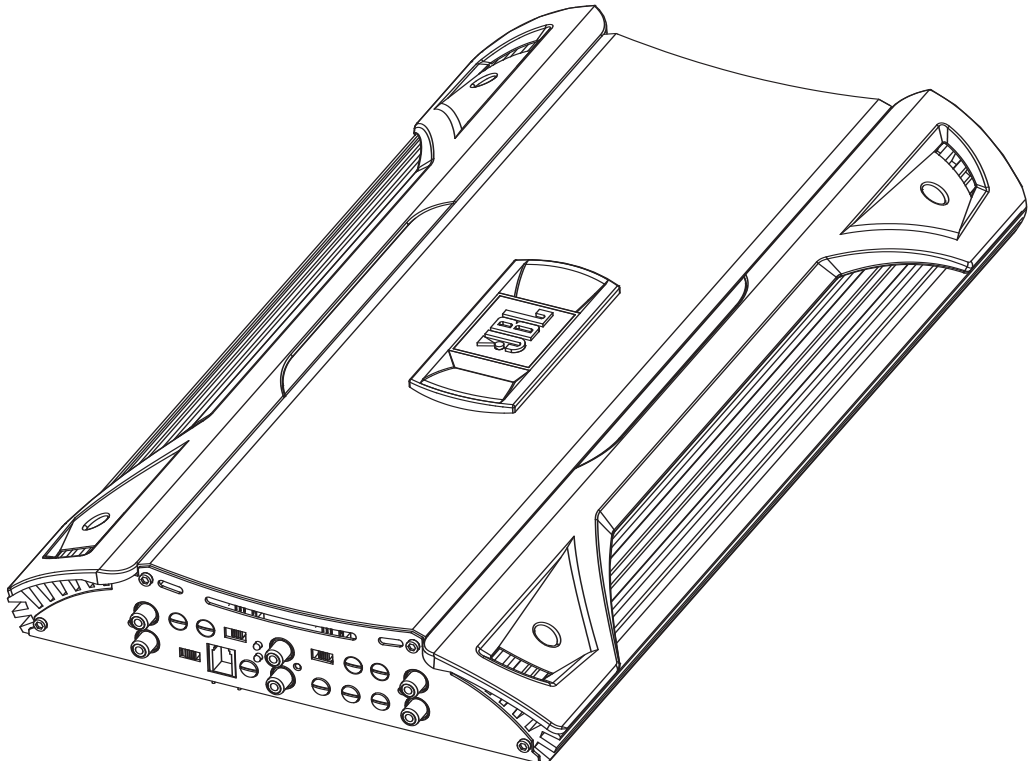

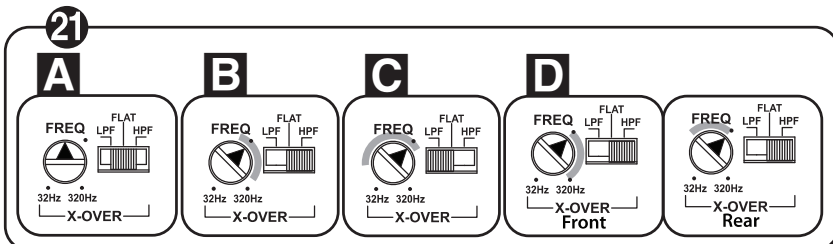
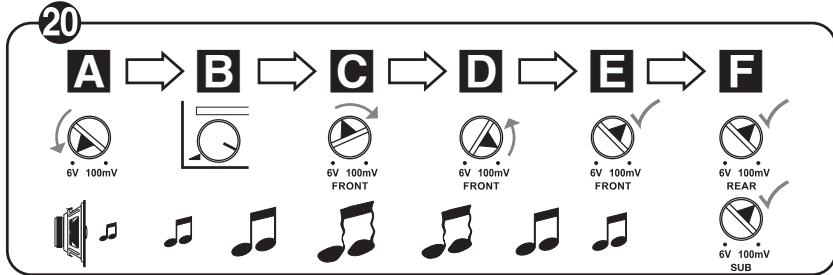
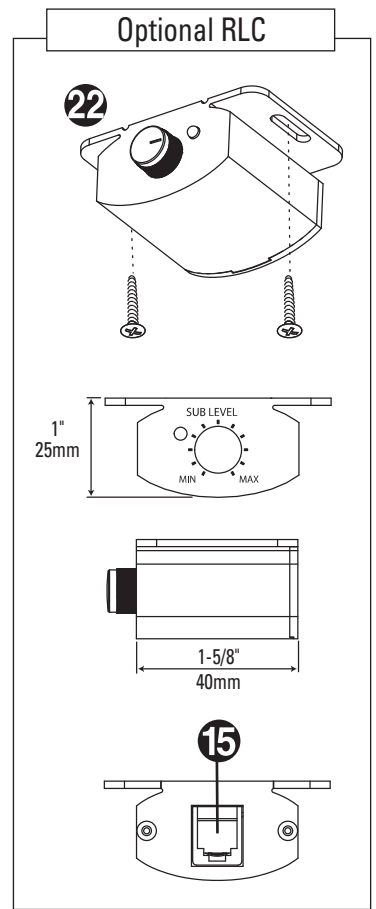
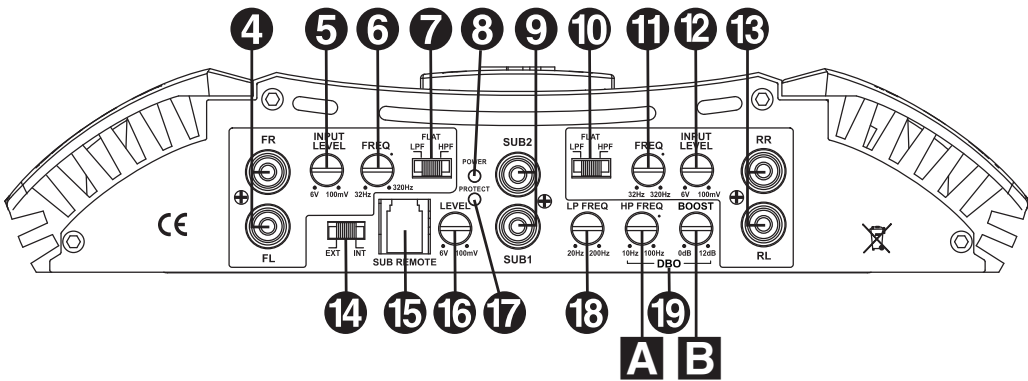
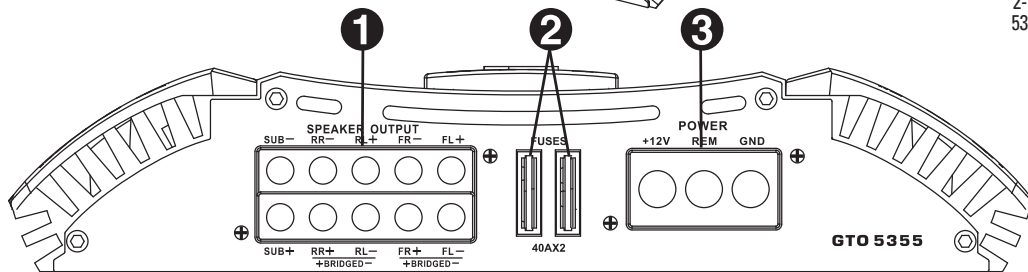
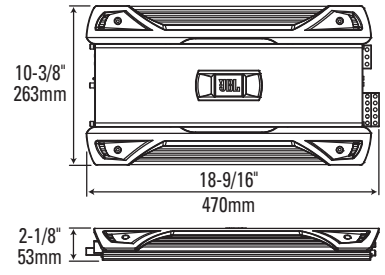
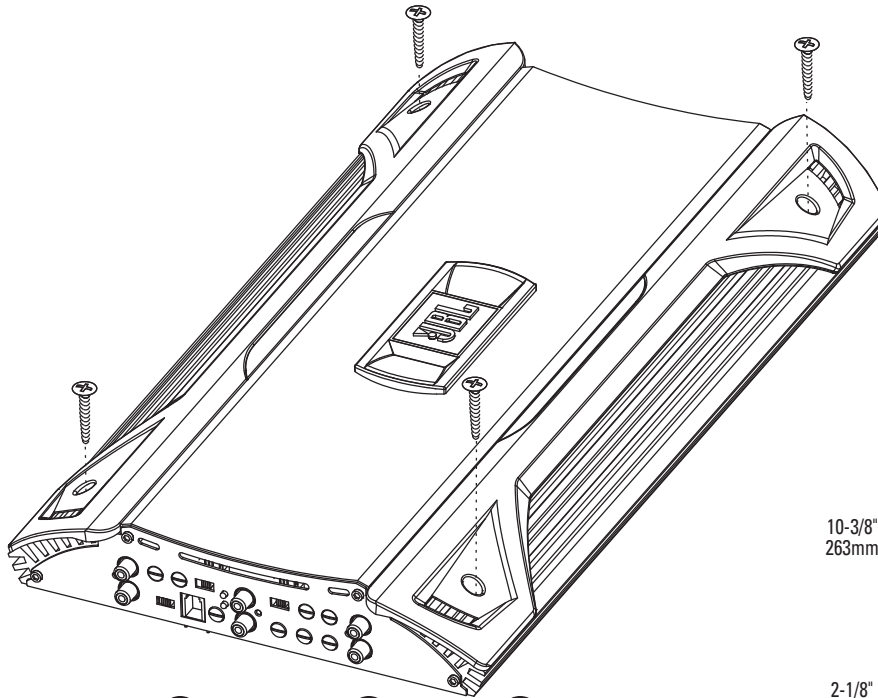
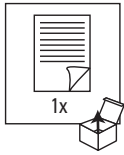

# GTO5355 CAR AUDIO POWER AMPLIFIER OWNER'S MANUAL

## Installation Warnings and Tips

- Disconnect the negative (–) lead from your vehicle's battery.
- At the installation sites, locate and make a note of all fuel lines, hydraulic brake lines, vacuum lines and electrical wiring. Use extreme caution when cutting or drilling in and around these areas.
- Choose a safe mounting location away from moisture.
- Make sure there is sufficient air circulation at the mounting location for the amplifier to cool itself.
- Mount the amplifier, using the supplied hardware.

## Specifications

- 55W RMS x 4 channels, plus 225W RMS x 1 @ 4 ohms and  $\leq 1\%$  THD + N\*
  - 75W RMS x 4 channels, plus 360W RMS x 1 @ 2 ohms, 14.4V supply and  $\leq 1\%$  THD + N\*
  - 150W RMS x 2 channels @ 4 ohms, plus 360W RMS x 1 @ 2 ohms, 14.4V supply and  $\leq 1\%$  THD + N\*
  - Frequency response: 10Hz – 83kHz and 20Hz – 250Hz (–3dB)
  - Maximum input signal: 6V\*
  - Maximum sensitivity: 100mV\*
  - THD + N: 0.03%
  - Signal-to-noise ratio: 85dB (reference 1W into 4 ohms)\*
  - Signal-to-noise ratio: 104dB (reference rated power into 4 ohms)
- \* CEA-2006A-compliant

## 1 Speaker Output Connectors

- Connect the speakers to these terminals, observing proper polarity.
  - Five-channel operation: Connect the front left speaker to the Front L+ and L– terminals and the front right speaker to the Front R+ and R– terminals. Repeat for the rear speakers, using the Rear L+ and L– terminals, and the Rear R+ and R– terminals. Connect the subwoofer to the Sub+ and Sub– terminals.
  - Four-channel operation: Connect the stereo speakers to the Front terminals, as above. Connect the single speaker into which the amplifier's rear channels will be bridged to the Rear R+ and Rear L– terminals. Connect the subwoofer to the Sub+ and Sub– terminals
  - Three-channel (bridged) operation: Connect one speaker to the Front R+ and Front L– terminals. Connect the other speaker to the Rear R+ and Rear L– terminals. Connect the subwoofer to the Sub+ and Sub– terminals.
- Minimum speaker impedance for stereo operation is 2 ohms. Minimum speaker impedance for bridged operation is 4 ohms. Minimum subwoofer impedance is 2 ohms.

## 2 Fuses

- Replace only with same type and rating.

## 3 Power Input Connectors

- +12V: Connect to the positive terminal of the vehicle's battery. 4 AWG wire is recommended. Install an appropriate fuse holder and fuse (80A minimum) within 18 inches of the battery. Make sure the wire is not damaged or pinched during installation. Install protective grommets when routing wires through the firewall or other sheet metal.

- GND: Connect to the vehicle's chassis. Refer to the picture below.

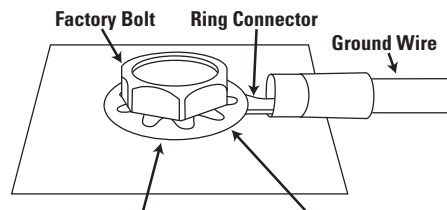

**Note: Remove any paint below ring connector.**

- REM: Connect to the "Remote Out" lead from the source unit or to a source of switched 12V+ (ACC).

## 4 Front Input Connectors (RCA)

- Connect to the front RCA outputs from the source unit or signal processor.

## 5 Front Input-Level Control

- Used to match the front input level of the amplifier to the output level of the source unit.
- See 20 for the adjustment procedure.

## 6 Front Crossover-Frequency Control

- 12dB/octave crossover, variable from 32Hz to 320Hz.
- See 21 for the adjustment procedure.

## 7 Front Crossover-Filter Selector

- LPF: Select for subwoofer(s).
- FLAT: Select for full-range speakers when no subwoofer will be used in the system.
- HPF: Select for midrange speakers or full-range speakers when a subwoofer is used in the system.

## 8 Power On LED

- Illuminated when the amplifier is on.

## 9 Subwoofer Input Connector (RCA)

- Connect to the subwoofer RCA outputs from the source unit, or signal processor.

## 10 Rear Crossover-Filter Selector

- LPF: Select for subwoofer(s).
- FLAT: Select for full-range speakers when no subwoofer will be used in the system.
- HPF: Select for midrange speakers or full-range speakers when a subwoofer is used in the system.

## 11 Rear Crossover-Frequency Control

- 12dB/octave crossover, variable from 32Hz to 320Hz.
- See the adjustment procedure in 21.

## 12 Rear Input-Level Control

- Used to match the rear input of the amplifier to the output of the source unit.
- See 20 for adjustment procedures.

## 13 Rear Input Connectors (RCA)

- Connect to rear RCA outputs from the source unit, or signal processor.

## 14 EXT/INT Switch

- If the source unit has a subwoofer output and you have connected it to the SUB input, set this switch to the EXT position. Otherwise, set it in the INT position.

## 15 Optional Subwoofer Remote Level Control Connector

- Connect the Remote Level Control (RLC) here, using the RJ-11 cable (supplied with the RLC).

## 16 Subwoofer Level Control

- Used to match the SUB input of the amplifier to the output of the source unit.
- See 20 for adjustment procedures.

## 17 Protect LED

- Illuminated under any of the following fault conditions: battery over/under voltage, short circuit in speaker wires, amplifier is too hot, amplifier's output circuit has failed (DC voltage present in the amplifier's output).

## 18 Subwoofer Low-Pass Filter Frequency Control

- 12dB/octave low-pass filter, variable from 20Hz to 200Hz.
- See the adjustment procedure in 21.

## 19 DBO (Dynamic Bass Optimization) Variable Subsonic High-Pass Filter With Variable Boost (Q)

- For woofers in tuned (vented) enclosures, set the Frequency control to a value 10Hz below the enclosure's resonance (tuned) frequency.
- For woofers in sealed boxes, set the control to any value you prefer between 30Hz and 50Hz.
- Set the Boost control according to your preference, being careful not to apply enough boost to damage your woofer(s).
  - A** DBO High-Pass Filter Frequency control, variable between 10Hz and 100Hz. See above for appropriate settings.
  - B** DBO Boost control provides up to 12dB of boost, slightly above the high-pass filter's frequency. See above for appropriate settings.

## 20 Setting Input Level

- A** Turn all Input-Level controls counterclockwise to 6V (minimum).
- B** With a dynamic music track playing, turn the head unit's volume control to the 3/4 position.
- C** Turn Front Input-Level control clockwise until the music is so loud that it no longer sounds clear (distortion is present in the output).
- D** Turn Front-Input-Level control counterclockwise gradually, just until the music sounds clear, once again.
- E** Front-Level input is now adjusted correctly.
- F** Adjust the Rear and Sub Input-Level controls so that the level of the rear speakers and the level of the subwoofer are proportionate to the level of the front speakers, according to your preference.

## 21 Setting the Crossover

- A** Crossover setting for 5" or larger full-range speakers when no subwoofer is included in the system.
  - B** Crossover setting for full-range speakers when a subwoofer is included in the system.
  - C** Crossover setting for subwoofers.
  - D** Crossover setting for systems that include separate mid-bass speakers driven by the rear channels, with the BP switch set to "BP"
- Note:** Acceptable frequency ranges are indicated in gray.

## 22 Remote Level Control (Optional)

- The Remote Level Control, if installed, will allow you to adjust the level of bass while seated in the listening position.

This product is designed for mobile applications and is not intended for connection to the mains.  
A valid serial number is required for warranty coverage.  
Features, specifications and appearance are subject to change without notice.



Harman International, Consumer Division  
8500 Balboa Boulevard, Northridge, CA 91329 USA  
www.jbl.com

© 2009 Harman International Industries, Incorporated. All rights reserved.

JBL is a trademark of Harman International Industries, Incorporated,  
registered in the United States and/or other countries.

Part No. GT053550M 3/08

**H** Harman International



Declaration of Conformity

**CE**

We, Harman Consumer Group, Inc.  
2, route de Tours  
72500 Château du Loir  
France

declare in own responsibility that the product described in this owner's  
manual is in compliance with technical standards:  
EN 55013:2001+A1:2003  
EN 55020:2002+A1:2003

*Klaus Lebherz*  
Klaus Lebherz  
Harman Consumer Group, Inc.  
Château du Loir, France 3/08