



<b>Introduction</b> .....	2
Features .....	2
About Installation .....	2
<b>Quick Start</b> .....	3
<b>System Design Using the GTQ190</b> .....	3
Speaker Requirements .....	3
Signal Sources .....	4
Other Components .....	4
Typical Applications .....	4
<b>Warnings and Tips</b> .....	5
Installation Precautions .....	5
Mounting Locations .....	6
<b>Installation and Use</b> .....	6
Controls and Connectors .....	6
Mounting Positions .....	7
Wiring .....	7
Power Supply Connections .....	7
+12V Battery Wire .....	7
Ground Wire .....	8
Remote Connection .....	8
Speaker Connections .....	8
Audio Input Connections .....	9
Line-Level Input Connections .....	9
Speaker-Level Input Connections .....	10
Simultaneous Speaker-Level + Line-Level .....	10
Mode Switches .....	10

<b>Adjusting the Gain</b> .....	11
<b>Other Important Characteristics</b> .....	11
<b>Add-On and Upgrade Steps</b> .....	11
<b>In Case of Difficulty</b> .....	13
<b>Solving Noise Problems</b> .....	13
System Noise .....	13
Vehicle Noise .....	13
<b>Specifications</b> .....	15
<b>Maintenance</b> .....	15

## Owner's Warranty Information

Model Number \_\_\_\_\_

Serial Number \_\_\_\_\_

Dealer Name \_\_\_\_\_

City, State, Zip \_\_\_\_\_

Sales Receipt Number \_\_\_\_\_

Date of Purchase \_\_\_\_\_

## Introduction

**Thanks** for purchasing your new GT series automotive multi-channel amplifier. Your GT series amplifier will easily connect to virtually any car audio system, whether it is factory installed or purchased separately. The GTQ190 includes an abundance of unique features which are described in this manual. The flexible design of its built-in crossover circuitry allows elaborate systems to be built more simply than with conventional components. For optimum performance, the power amplifier circuitry is a fully-discrete design notable for its low distortion and unusually clean and clear sound quality. In addition to conventional preamp-level inputs, the GTQ190 features JBL's Universal Interface, which facilitates simple connection to factory radios with the low distortion that is usually only associated with preamp-level connection. With the Universal Interface,

a factory radio can either be used as the main music source or simultaneously combined with a CD player or changer that has volume-control capability. By providing this two-unit direct connection, Universal Interface circuitry eliminates the need for an FM modulator to interface a CD player to factory radios, improving the fidelity of digital playback. In addition, when using a high-powered (BTL) radio through the speaker-level inputs, Common Sense turn-on circuitry senses the common-mode voltage present on the radio's speaker wires, turning the amplifier on without an additional remote wire.

Also, the built-in active crossover provides either full-range, high-pass or low-pass operation. This lets your GT series amplifier power either subwoofer or component speakers in a bi-amplified system, or conventional full-range speakers in simpler systems.

The GTQ190 also includes preamp-level outputs which provide a full-range signal to drive additional amplifiers. This lets you build systems of virtually any design without requiring a separate electronic crossover.

## Features

- 4-, 3-, or 2-Channel Operation
- Simultaneous Stereo + Mono Operation
- 2 Built-In Independent 18dB/Octave Frequency Selectable High-Pass and Low-Pass Crossovers
- 2 Pairs of Preamp Outputs
- No Current Limiting
- Oversized Floating Rail MOSFET Switch-Mode Power Supply
- "Common Sense" 2-Way Turn-On with Remote-Out Capability to Turn On Other Amplifiers or Signal Processors
- Switchable Bass Boost
- "Stealth Remote" Silent Turn-On Circuitry with Power-On Indicator
- Balanced Speaker-Level Inputs
- Mute Input – Accepts Standard Noise Gate Input to Silence the Amp During No Music Conditions
- 2 Continuously Adjustable Gain Controls
- Capable of Single-Ended Operation into 2-Ohm Loads
- Fully Complementary, Direct-Coupled, Discrete Power Amplifier Circuitry
- Gold-Plated RCA Input Connectors
- Gold-Plated Power and Speaker Connectors
- Third Order (18dB per Octave) Capacitive/Inductive Power-Supply Filtering
- Independent Input Mode Switching for Each Group of Channels
- Made in USA

## About Installation

Although the GTQ190 is designed to make installation as easy as possible, this is an extremely sophisticated product that requires proper installation and setup to realize its full performance potential. Skill with tools, an understanding of basic electronics, and experience with car stereo installation are needed to properly install this amplifier. If you feel you do not have the necessary knowledge and skills, **we strongly recommend that the installation be done by your authorized JBL dealer.** If the GTQ amplifier is installed by an authorized JBL dealer in the USA, we will **double the length of your warranty to two years from date of purchase. Please retain a copy of your bill of sale to ensure this additional coverage.**

If you choose to install the GTQ amplifier yourself, read **all** of the information in this manual **before** you start the installation. Pay particular attention to the safety precautions and notes.

It will save potential problems later if you take a few minutes to plan the complete installation before you start. The routing of wires, the power supply connection points, and the mechanical installation of the unit should be completely thought out before you begin. Work carefully and check each step as it is performed. Before operating the amplifier, recheck the entire installation to be sure that each connection is correct, properly insulated and secure.

## Quick Start

### Recommended for Experienced Professional Installers Only!

1. Disconnect the negative cable from the battery. Note: If the vehicle's radio features a code-type security system, make certain you know the code before disconnecting the battery!

2. Run a power cable complete with a fuse (not included) directly from the positive +12V battery terminal to the desired amplifier location. Keep the fuse within 6" of the battery terminal, and position it before the wire runs through any metal partition. A minimum of #10AWG is required for the GTQ190, as is a 30A fuse.

**Note:** All wiring connections should be made either by soldering with heatshrink tubing insulation, by using commercially available high-quality distribution blocks, or with high-quality crimp-type insulated connectors installed with a professional-type, articulated crimping tool. Soldering crimp-type terminals is recommended for additional security. Never use wire nuts, insulation-displacement connectors (i.e., ScotchLok type), or twist and tape connections. Do not use electrical tape; it will loosen with age and extreme temperatures.

3. Mount amplifier in the desired location using the included screws.

4. Connect power wiring as shown in the Wiring Diagram on page 7.

5. Connect the outputs from the head unit to the appropriate inputs of the amplifier according to the Wiring Diagram (page 7) with either (or both) high-quality low-level signal cables with RCA plugs, or the supplied speaker-level input connector.
6. Connect the speakers to the amplifier according to the Wiring Diagram on page 7.
7. Turn the gain controls to the 1/4-position for all groups.
8. Set the bass boost of each group to the desired position.
9. Set the crossover switches for each group as desired.
10. Set the Group 2 Input as desired.
11. Set the mode switches to Stereo, Left + Right, or Left Input Only operation for each group.
12. Double-check your switch settings. Reconnect the negative battery cable. **Note:** Incorrect switch settings can damage your speakers!
13. Turn on the signal source at a low volume level, and check for the correct output from each speaker.
14. Adjust the amplifier gain controls using the procedure described in the "Adjusting the Gain" section (page 11).
15. Read the rest of the manual to get maximum use and enjoyment from your amplifier.

## System Design Using the GTQ190

### Speaker Requirements

When used in the non-bridged mode, a group-channel of the GTQ190 can easily drive two 2-ohm speaker loads. When only one speaker is connected to the left and right outputs of a group, virtually any conventional speaker may be used. When two speakers are connected in parallel to a single output (left or right) of a given group, each speaker must have a minimum impedance of 4 ohms. This ensures that the combined load will not drop below 2 ohms. Although the amplifier will not be damaged, load impedances lower than 2 ohms will eventually cause the amplifier to overheat, activating the protection circuits and causing the unit to shut off until it cools down sufficiently. When a group is in bridged mode, the combined impedance of the speaker (or speakers) connected to the bridged channels should be at least 4 ohms. As in the example above, sustained operation of the unit in bridged mode with less than 4 ohms will likely cause overheating. If monaural operation is desired, and two 4-ohm speakers are used, it is best to connect each speaker to an individual amplifier output (left and right) and use the L+R mode on the mode switch to provide monaural operation. **The GTQ190 must not be used with speakers that have either one of their input terminals wired to the frame of the speaker or to the chassis of the vehicle.**

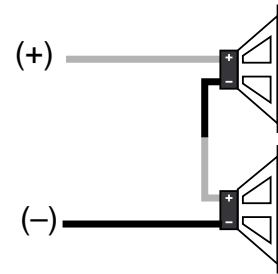
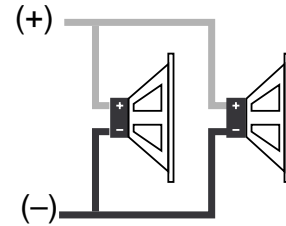

## Signal Sources

The low-level preamp outputs of any radio/tape deck, CD player, or preamp/ equalizer so equipped can drive the GTQ190. The gain controls of the amplifier are used to match its input sensitivity to the output voltage of the source. This matching is important to keep noise low and is explained in the "Adjusting the Gain" section of this manual (see page 11).

Thanks to Universal Interface Circuitry, the GTQ190 can also be connected to power amplifiers, radios or equalizers that are equipped with only speaker outputs by connecting them through the speaker-level input connector. Inside the GTQ190, the speaker-level and preamp-level inputs are connected through a mixing circuit, which allows them to be used simultaneously. Therefore a low-level source, such as a CD player equipped with a volume control, may be connected to the preamp-level inputs at the same time as a powered radio/tape unit is connected to the speaker-level inputs. This provides a higher performance alternative to an FM modulator connection when you wish to add CD capability to a factory cassette stereo. Switching from one source to the other is as simple as turning the desired source on and turning the undesired one off — no additional switches or relay connections are needed.

## Other Components

The system options of the GTQ190 are numerous. All JBL amplifiers are designed with sufficient adjustment range to match with the accepted normal voltages and impedances used by virtually all car audio components. With very few exceptions, the GTQ190 will match up with nearly any equipment you already have.

## Typical Applications

The diagrams on pages 4 and 5 show the most common basic system configurations of GTQ amps. One or more of these building blocks may be combined to form elaborate system designs. For additional ideas, refer to the "Add-On and Upgrade Steps" section (see page 11).

GTQ amps use the terminology "Group 1" and "Group 2" to indicate the two main signal paths within the amplifier. Each "group" may consist of a mono bridged signal or a stereo pair of L+R signals depending on the system configuration.

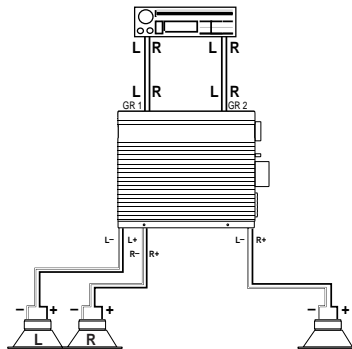
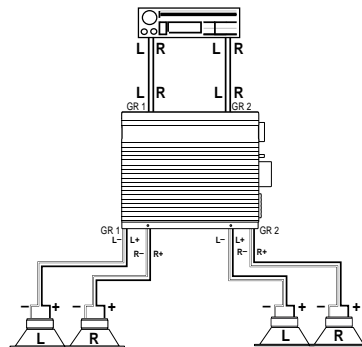

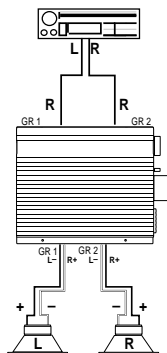
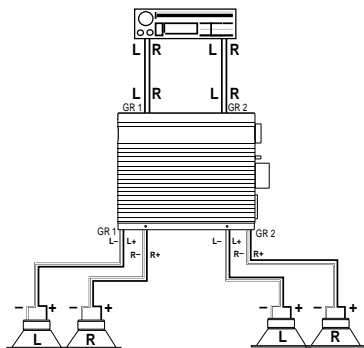

## Warnings and Tips

### Installation Precautions

Before beginning the installation of the amplifier read the following points carefully. Failure to heed these warnings could result in personal injury or damage to property.

- The unit should be installed only in vehicles that have 12-volt negative ground electrical systems. Connection to other types of electrical systems may damage the amplifier and/or the vehicle's electrical system.

- Before beginning the installation, disconnect the negative (ground) cable from the vehicle's battery. This will prevent accidental short circuits while working on the installation. Reconnect the cable only after the installation is complete and the wiring has been carefully checked to be sure there are no exposed wires or short circuits and everything is properly and securely connected. **Note:** If the vehicle's radio features a code-type security system, make certain you know the code before disconnecting the battery!

- Work in an area that is well-ventilated.
- Wear eye protection whenever cutting, drilling or filing any parts of the vehicle.
- Wear ear protection when using high-speed drills, saws, sanders, or grinders.

We want you to be able to enjoy the

system once it is installed.

- Before cutting or drilling any holes in the vehicle, inspect the area carefully to be sure there are no electrical wires, hydraulic brake lines, fuel lines, or fuel tanks that may be damaged while doing so. Such components may be hidden within double-walled panels or structural members of the vehicle, so be extremely cautious.

- Do not bypass or modify the fuses on the chassis of the amplifier. Do not replace a fuse with one rated for higher current levels. Doing so could result in damage to the amplifier or to the vehicle's electrical system. Repeated blowing of the power supply fuse indicates a problem within the amplifier or improper installation.

- An additional power supply fuse (not included) must be located as close as possible to the battery on the +12V wire to minimize the chance of electrical system damage or fire. Do not ignore this precaution! If the heavy gauge power wire required with the GTQ amplifier ever becomes shorted to ground, the wire will get extremely hot, causing the insulation to burn off and will likely cause a fire if not properly fused.

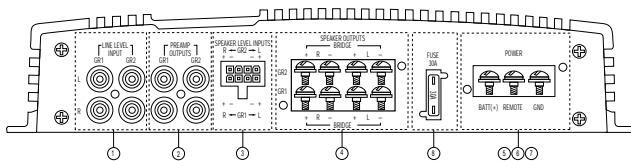

## Mounting Locations

There are several factors to consider when selecting a mounting location for a GTQ amplifier.

- It must be securely mounted in a place where it will not be subjected to excessive shock and vibration.
- Under no circumstances should the amplifier be mounted where it will be exposed to moisture or extreme heat.
- Try to mount the amplifier where the main +12-volt power supply terminal, which must be connected directly to the battery, can be kept relatively short.
- GTQ amplifiers must be mounted in a place where air can circulate around the fins on the chassis. Good air circulation around the amplifier will make it operate at lower temperatures and reduce the chance of the thermal protection circuits being triggered. The installation positions that provide the most efficient air circulation around the amplifier are shown on this page.
- Use a mounting location that allows access to the wiring connections and level adjustments. This allows the unit to be mounted before these connections and adjustments are made. If the amplifier must be mounted in an inaccessible location, it may be easier to mount it after the wiring connections and level adjustments are complete.

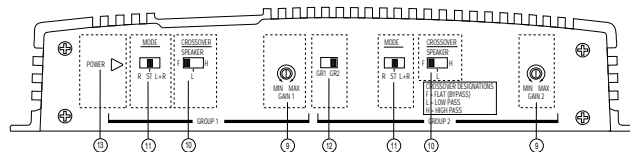
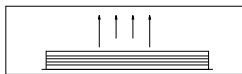
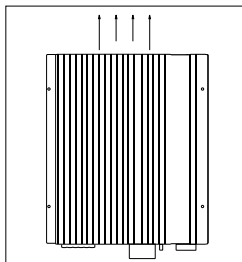

## Installation and Use

### Controls and Connectors

1. **Preamp-Level Input Connector** – Use these connectors for line-level (preamp) inputs to the amplifier.
2. **Preamp-Level Output Connector** – Use these outputs to send fixed full-range signal to additional amplifiers.
3. **Speaker-Level Input Connector** – Use this connector for speaker-level input signals. A wire harness is supplied for use with this connector. See “Audio Input Connections” section (page 9) for wiring instructions. This input also includes JBL’s Common Sense input circuitry which turns the amplifier on as soon as the high-powered head unit connected to this input is turned on.
4. **Speaker Output Connectors** – Connect speaker wiring to these connectors. See wiring directions (page 7) for more information.
- 5., 6., 7. **Power Connector** – Connection for power wires and Remote. See wiring directions (page 7) for information on proper connections.
8. **Fuse** – 30A ATC type.
9. **Gain Controls** – Use these controls to adjust the gain of the amplifier channel group. See the “Adjusting the Gain” section (on page 11) for tips on proper setup.
10. **Speaker Crossover Switches** – These switches control the built-in crossovers

that are connected to each group’s power amplifier circuitry. Set the switch to F (flat) for full band operation on a group. Set this switch to L (low) to activate the low-pass filter on the selected amplifier group for subwoofer use or to use in conjunction with a high-pass filtered input signal to create a band-pass crossover (for a midrange or midbass driver). Set the switch to H (high) to activate the high-pass filter for use with satellite speakers or tweeters on an amplifier group.

11. **Mode Switches** – These switches are used to set the input mode for both preamp and speaker-level inputs. Set the switch to ST(ereo) for normal operation on the group using individual left and right inputs. Set this switch to R to drive both the left and right outputs with only a single input on the left jack. Set the switch to L+R to sum the left and right inputs for a mono output on the group. These switches do not affect the preamp outputs.

12. **Group 2 Input Switch** – This switch is used to select which inputs will drive Group 2 of the amplifier. Put the switch in position “GR 1” to allow Group 2 to be driven by the Group 1 inputs. Put the switch in the “GR 2” position to drive Group 2 with the Group 2 inputs.

13. **Power Indicator LED (on amp chassis top)** – LED steadily illuminates for normal operation. LED blinks when protection circuitry or muting is engaged.

## Mounting Positions

Place the amplifier in the installation location. Use a pen or pencil to mark the mounting screw hole locations. Set the amplifier aside and drill the holes for the mounting screws. (**Note:** If the surface you are mounting the amp to is covered with carpeting or upholstery, cut a small "x" in the material at each screw hole location before drilling the holes. This will help prevent tearing or stretching of the material and carpet fibers from being pulled out.) Set the amplifier in position and align the holes on its side with the holes previously drilled. Put washers on the sheet metal screws provided and drive them into the mounting panel. Tighten the screws evenly until the unit is securely mounted.

## Wiring

Proper wiring of the GTQ amplifier and the associated components is extremely important for proper performance and long-term reliability. Using the proper type of wire is very important. If a specific type of wire is required for a certain application, it will be noted. Route the wiring through the car carefully. Do not allow wires to lay against sharp sheet metal edges or any other surfaces that might wear away or cut through the insulation of the wire. Use insulated strain reliefs, rubber grommets and plastic tubing to protect the wires whenever they are run through sheet metal panels or are placed where they might be pulled or damaged.

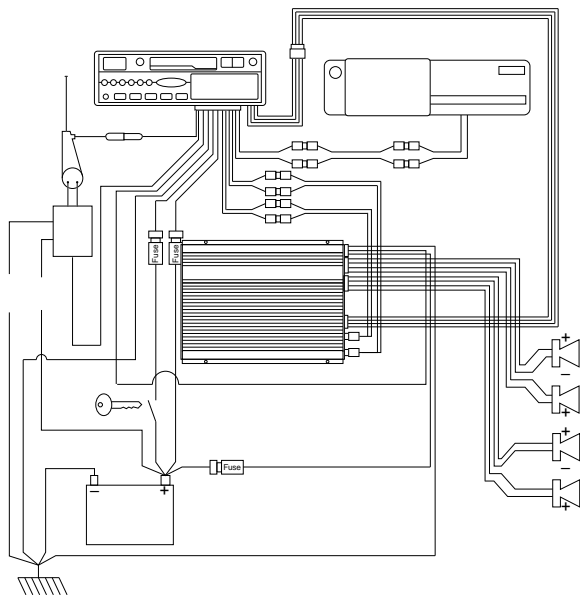

## Power Supply Connections

The power input and remote turn-on wires are connected to the GTQ amplifier via the power connector on the end of the amplifier.

### +12V Battery Wire

- Connect a wire directly from the +12 volt terminal of the battery to the + Battery terminal on the amplifier. Use a minimum of AWG #10 for the GTQ190. Use wire that is heat- and oil-resistant whenever running wires through the engine compartment. All wire-to-wire connections should be soldered and insulated with heatshrink tubing, or connected through a high-quality insulated crimp-on connector or secure set-screw-type terminal blocks. Never leave bare wire exposed. Terminate wires with crimp or solder-on lug terminals whenever appropriate.
- GTQ amplifiers will draw large amounts of current from the vehicle's electrical system, enough to overload conventional vehicle wiring. Therefore the +12 volt power supply must be taken directly from the positive side of the battery. **Do not connect to the vehicle's fuse block or to a wire feeding other accessories.**
- To prevent electrical system damage or fire, a fuseholder and fuse (not included - 30 amps) must be installed in the power supply wire as close to the battery as possible, and before the wire travels through the firewall or other metal panel.

## Ground Wire

- Proper grounding is extremely important. Use a heat- and oil-resistant stranded copper automotive wire equivalent to the size used for the +12V connection. Crimp or solder and insulate any wire-to-wire connections. Keep the ground wire as short as possible. A ground wire must be solidly connected to a major sheet-metal structure of the vehicle such as a panel near the amp-mounting location. Scrape all paint and primer off the sheet metal at the grounding point to ensure a good electrical connection. Attach the wire to the grounding point with a nut, bolt and star washer. The high current demanded by high-powered amplifiers requires a more secure ground than the typical sheet-metal screw will provide. Coat the connection with silicon sealant for better long-term reliability.
- In some vehicles, such as those that have non-metal bodies, it may be necessary to use a long ground wire and connect it to a frame rail or even directly to the negative (-) terminal of the battery.

- When installing elaborate systems with multiple components, it is common practice to ground all of the amplifiers and signal processors to the same point to prevent noise pickup from a ground loop. With the extremely high peak current demands of high-powered amplifiers, this can result in unstable power delivery to the components, due to modulation of the power ground point by the high power demands. The advanced, isolated power supply used in the GTQ amplifiers makes common ground installation to prevent ground loops unnecessary. They can be grounded close to their mounting positions. Use of heavy gauge wire for all grounding, even signal processors and head units, can minimize possible noise pickup.

## Remote Connection

- The remote power control system turns the GTQ amplifier off when not in use to prevent discharging of the vehicle's battery. Because the JBL GTQ amplifiers include Common Sense 2-way turn-on, when using the speaker-level inputs with a head unit that includes a BTL power amp it is not necessary to connect the remote wire. The amplifier will automatically activate whenever you turn on the head unit. If you are using the line-level inputs, or the speaker-level inputs with a head unit that does not have a BTL power amp, use the following remote wire connections.

- **Using the Remote feature** – When +12 volts is applied to the remote IN/OUT terminal the amplifier is turned on. A red LED on the top panel of the amplifier will illuminate to indicate the amplifier is on. If the head unit has a +12 volt automatic antenna or amplifier remote activation wire, connect it to the REM-IN/OUT connector on the GTQ amplifier. When the amplifier is turned on, there is a time delay of several seconds (longer in cold weather) before the amplifier will produce sound. This eliminates the chance of annoying noises produced by the radio or signal processors being amplified and passed to the speakers when the system is first activated.
- Some head units have no automatic antenna or power amp activation wire. Others have automatic antenna wires that are “on” only when the radio is used but not when a tape is played. In such cases, connect the remote-in turn-on terminal to an unused accessory terminal in the fuse block, or any other +12 volt source that is turned on and off with the vehicle's ignition switch. The remote on/off system draws negligible current so a relatively small (18 or 20 gauge) wire may be used.

## Speaker Connections

- When connecting speaker wires, be sure that no uninsulated wire remains exposed and no loose strands of wire touch either an adjoining wire or terminal or a metal surface. Securely crimp or solder all connections and insulate them with heatshrink tubing.

- Use high-quality 18-gauge or larger speaker wire for the amplifier-to-speaker connections. Larger wire or special high-performance speaker cables may improve the performance of some systems.
- Be very careful when speaker wire is routed through a door hinge area to door-mounted speakers. Use grommets and strain reliefs wherever necessary to prevent damage to the wires.
- The proper speaker connection depends on whether a group of the GTQ amplifier is used bridged or stereo. In either configuration the speakers are connected to the speaker output connector.
- To get proper bass response and stereo imaging, all the speakers in the system must be in phase. The input terminals of the speakers will be marked in some way to identify positive and negative polarity. Make sure that the positive (+) speaker terminal is attached to the positive (+) amplifier connection in every speaker-to-amp connection. All two-conductor speaker wire has one conductor marked in some way so it can be easily traced.
- **Stereo Connection** – Connect each speaker to appropriately labeled terminals of the speaker output connector.
- **Bridged-Mode Connection** – Connect the loudspeaker positive (+) terminal to the RIGHT positive amplifier speaker output terminal on the group to be bridged. Connect the loudspeaker negative (-) terminal to the LEFT negative amplifier speaker output terminal on the group to be bridged. The appropriate group mode switch should be set to LEFT or L+R.

### • Simultaneous Stereo + Mono Connection-

Each of the two groups of the GTQ amplifier may be used to drive a stereo pair of speakers with a mono speaker at the same time. This is sometimes used for center-speaker applications or for inexpensive subwoofer addition with two-output amplifiers. Unlike a true bi-amplified subwoofer connection, however, this type of system configuration does not provide fine control of subwoofer-satellite balance. It requires the use of a passive subwoofer crossover instead of the superior active circuitry already built into GTQ amplifiers, and it does not separate the power amps driving the satellites from the amps driving the subwoofer. With the 4 speaker outputs already available on the GTQ amplifier, a stereo + mono connection for subwoofers should not be necessary. If you wish to add a center speaker, connect the main pair of stereo speakers as in the stereo mode; connect the mono speaker as indicated on page 9 for bridge-mode connection. A high-power L-Pad or power fader can be used to attenuate the center channel for proper level matching. Each speaker should have an impedance that is equal to or greater than 4 ohms. The input-mode switch for the channel pair being used in Simultaneous Stereo + Mono should be set to STEREO.

### Audio Input Connections

#### Line-Level Input Connections

• Proper wiring between the signal source, any other components in the system, and the GTQ amplifier will help keep noise levels in the system low. Use high-quality, twisted-pair cable or low-capacitance shielded wire.

Keep the wire as short as possible. Do not splice together shielded wires. Do not run audio signal wires alongside power wires for an extended length either for the amp or the vehicle's standard power wires. When wires are run for long distances, separate the audio signal wires from power supply wires or vehicle wiring harnesses as much as possible. When signal wires and power wires must cross, try to keep them perpendicular. Avoid routing any wires near accessories such as ignition control modules, tachometers, fuel pumps or fan motors.

• The line-level inputs of GTQ amplifiers accept standard phono plugs (also called RCA plugs). The outputs of most head units, equalizers, or crossovers also accept phono plugs. If another type of connector is used, adapters or special cables may be needed. Proper wire and connectors can be obtained from any JBL authorized installation specialist.

• **Note:** GTQ amplifiers have 2 built-in frequency-selectable low-pass crossovers and also 2 frequency-selectable high-pass crossovers. Be sure the crossover preamp switches for each group and the preamp outputs are properly set for the chosen system configuration (see "Typical Applications" and "Add-On and Upgrade Steps" sections for suggestions). If you have any questions about how to set the crossover switches, contact your local JBL dealer.

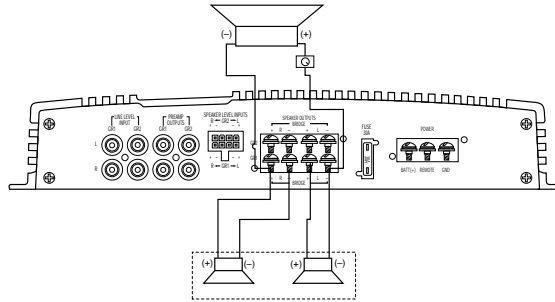
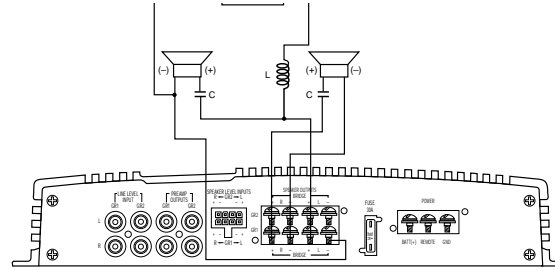

Simultaneous Stereo-Mono Connection Diagrams

## Speaker-Level Input Connections

When speaker-level signal is used to drive the GTQ amplifier, the signal goes into the amp through a special eight-wire harness/connector (see the “Controls and Connectors” section). If extension wires are needed between the head unit output and the amplifier unit, use conventional speaker wire or twisted-pair wiring. Keep the wiring inside the passenger and trunk compartments, and make the wires as short as possible. All connections should be securely crimped or soldered and insulated with heatshrink tubing.

- Use the color code of the input harness wires and the identification on the radio/tape deck output wires to be sure that left and right channels are correctly connected and the positive/negative polarity of each channel is connected correctly. For example, the left positive output of the head unit must be connected to the left positive input of the GTQ amplifier.

- The Universal Interface Speaker-Level Input may also be used to accept the signal from a preamp-level balanced-line driver capable of at least 4V output. To utilize this option, terminate the signal leads from the balanced line driver to a Molex Mini-Fit Jr series 8P connector. The color code for the speaker-level input harness is as follows:

## Speaker-Level Input Harness

### Color Codes

Group 1 Left (+):	White
Group 1 Left (-):	White with Black Stripe
Group 1 Right (+):	Gray
Group 1 Right (-):	Gray with Black Stripe
Group 2 Left (+):	Green
Group 2 Left (-):	Green with Black Stripe
Group 2 Right (+):	Purple
Group 2 Right (-):	Purple with Black Stripe

## Simultaneous Speaker-Level + Line-Level

In some systems it may be desirable to use both the speaker-level inputs and line-level inputs simultaneously. For instance, if you have a stock head unit in your car you may connect the speaker-level inputs of the head unit to the GTQ amplifier. You may simultaneously connect a CD player equipped with a volume control to the preamp-level inputs of the GTQ amplifier. **Note:** Front & rear channels of the radio/tape and the CD player must be driven into the group 1 and group 2 inputs of the amp (use Y cables if necessary). The group 2 input switch must also be set to the group 2 position. The Universal Interface circuitry of the GTQ amplifier will isolate the inputs from each other while mixing both

signals. Therefore switching from one source to the other is as simple as turning the unused source off, and turning the desired source on. No other switches or relay boxes are needed. When using this setup it is also possible, using the wiring setup shown below, to allow either of the two sources to remotely turn on the amplifier. This is not necessary if the factory radio is of the high-power BTL type. The Common Sense turn-on circuit will activate the GTQ amplifier when using the powered source, and the conventional remote connection of the preamp-level source will activate the amp when it is used.

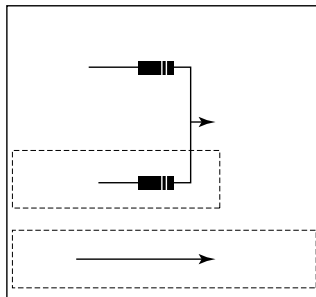

## Mode Switches

These switches are set according to the number of inputs connected to the amplifier group and the desired mode of operation. See the diagrams on pages 4 and 5, and the descriptions below for options.

- **Conventional Stereo Operation** – Set the appropriate group mode switch to ST for stereo. Connect the preamp-level head unit outputs either to the two gold line input connectors or connect the head unit speaker outputs to the speaker-level inputs. When using two head units, both the speaker and preamp-level inputs may be used simultaneously. Be sure to maintain left and right channel consistency.

- **Bridged Mode Operation** – To select bridge mode operation, set the mode switch for the appropriate group in either the L only or L+R position. In the L position, signal from the left input is fed to both left and right amplifier outputs for that group. In the L+R position, the signal from both the left and right inputs is summed internally. When using a group of the GTQ amplifier for mono mode fed with a stereo signal it is best to use the L+R mode.

When feeding a single GTQ amplifier channel group with a mono signal from an outboard crossover, use the L mode and connect your source input to the left input of the desired group to be used in bridged mono.

- **Simultaneous Stereo + Mono** – Set the Mode switch for the appropriate group to the stereo position. Main speakers are connected normally to the left and right stereo outputs of the group, and a center speaker or subwoofer speaker is connected to the same group as in bridged mode. Refer to the diagram on page 9 for connection details.

## Adjusting the Gain

Before operating the GTQ amplifier, recheck all wiring connections to make sure they are correct and secure. Be sure that a fuse (not included) is installed in the +12V line near the battery. Reconnect the negative ground (-) terminal of the battery. Make sure that the mode switches, crossover switches, Group 2 Input switches, and crossover frequency modules are properly set.

- The setting of the gain controls on the GTQ amplifier is important to ensure proper performance, low noise levels, and maximum reliability in the system. As a general rule, controls on components at the front-end of the system (source, equalizers, electronic crossovers, etc.) should be set as high as possible, with the amplifier gain control set as low as possible while still providing adequate volume levels. Using a high signal level from the source and a low gain setting on the amplifier will help keep background noise levels in the system low.

- To adjust a system using a single GTQ amplifier, start with both of the amplifier gain controls fully counterclockwise. Some head units have additional output level controls or switches. Set those to their maximum position.

- Set the level controls on any associated equipment such as equalizers and electronic crossovers as recommended by their manufacturers. Set all bass/treble or equalizer controls to their centered or bypassed positions. While listening carefully to the system output, adjust the volume control of the radio/tape deck to the point where you first begin to hear

audible distortion. **Use caution: excessive distortion can damage loudspeakers.**

Reduce the level just to the point where the distortion goes away. This is the maximum undistorted output level of your head unit and signal processors, and should not be exceeded during use. If audible distortion does not occur, continue to increase the level until the head unit is turned all the way up. If this setting does not provide adequate volume levels, gradually increase (turn clockwise) the gain control for the main (usually front) speaker groups on the GTQ amplifier until the system plays as loud as necessary or when the first signs of distortion are heard.

- After adjusting the main speaker's gain control, you may then turn down the head unit's volume control to a comfortable level, and adjust the remaining channels for the desired system balance. You will find this easiest to do by adjusting the channels in the following order: 1) front speaker group, 2) rear speaker or subwoofer group. Elaborate systems incorporating tri- or quad-amplification can be complex to adjust. Your local authorized JBL installation specialist is the best person to help with such adjustment.

## Other Important Characteristics

**Power Consumption** – Operating the GTQ amplifier when the vehicle is not running may discharge the battery. At high volumes, the amplifier can draw as much as 60 amps for brief bursts. After even a short period of time, this current drain can discharge the battery to the point that it will not start the vehicle. Although power consumption under no signal conditions is less than a few amperes, even this small power usage can discharge a battery over several hours. When GTQ amplifiers are turned off, there is no current drawn from the battery despite the direct-to-battery power connection.

**Overload Protection** – GTQ amplifiers incorporate elaborate protection circuitry to prevent damage to the amplifier circuitry and ensure reliable operation. This circuitry will turn the amplifier off in the event of overheating, a short circuit on the speaker output wiring, or improper power supply connections. If the amplifier cycles on and off, or does not work at all, a problem in installation or an abnormal electrical condition is indicated. Check speaker wiring for short circuits or impedance loads significantly below 2 ohms (4 ohms in bridged mode). Check the power supply voltage at the input of the amplifier to be sure that it is normal (between 11 and 16 volts). Check that the power wires are not reversed.

If the GTQ amplifier is operated at very high power levels in a high ambient temperature situation, the unit may not

be able to radiate all the heat generated by such operation. If the temperature of the amplifier reaches a level that could cause damage, the thermal overload protection circuit will turn the amplifier off. It will turn the amp back on again when it cools off. Repeated activation of the protection circuits indicates that the system is being improperly operated or that the amplifier should be relocated to an area that either has a lower ambient temperature or one which allows more air circulation around the unit.

**Fuse Replacement** – If the fuses on the GTQ amplifier must be replaced, DO NOT use a fuse rated for higher current levels. Exceeding the standard fuse size or bypassing the fuse holder will void the warranty and may cause serious damage. It is extremely rare for this fuse to blow. If it blows repeatedly, it is most likely that the amplifier has an internal problem that will need to be repaired by an authorized service center. The only external cause for this fuse to blow is reversed polarity of the power wire connections.

## Add-On and Upgrade Steps

The flexibility of GTQ amplifiers lets you design and build systems of high sophistication with only 1 or 2 amplifier chassis. It is impossible to cover all of the possibilities in this manual. Shown here are three examples of system configurations using GTQ amplifiers. Use these examples and your imagination to build systems of advanced design and performance.

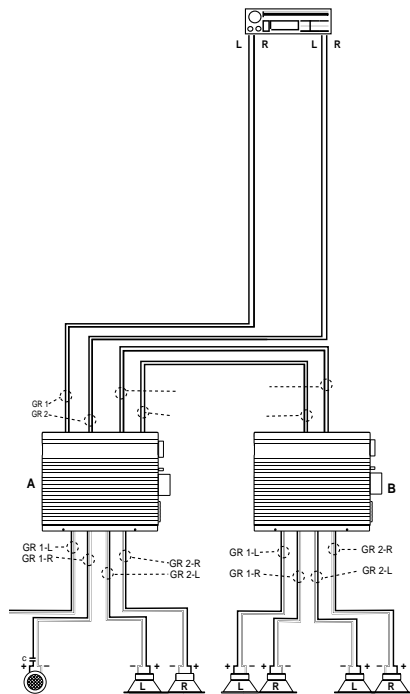
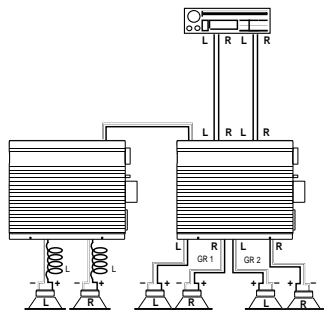
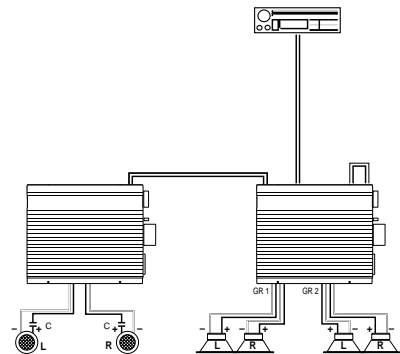

## In Case of Difficulty

### Power-on light does not come on

- Head unit not on; turn the head unit on.
- Ground wire is disconnected or defective; check for continuity with an ohmmeter between the amplifier's ground terminal and a known chassis ground point.
- Battery wire is disconnected or defective; check for approximately +12 volts between the amplifier's battery and ground terminals.
- Blown fuse: check amplifier's fuses located on the end panel near the power connector. If they are blown, replace them with identical ones. If the new fuses blow immediately, check all the wiring connections. If the source of the problem cannot be determined, consult your JBL dealer.
- Remote-on wire between the head unit and the amplifier is disconnected or defective; check for +12 volts between amplifier's remote-on input terminal and the ground wire with the head unit on.

### Power light is on, but no sound is heard from some or all of the speakers

- Incorrect switch settings; make sure that all switches (mode, input and crossover) are in their correct positions for your system configuration.
- Incorrectly connected or shorted speaker wires; check for shorts in wiring.
- Defective or disconnected audio cables; check for continuity and replace if necessary.
- Incorrect gain adjustment; verify that the amplifier gain controls are not turned completely down. If they are, sound output level may be very low and may give the impression that the system (or part of the system) is dead.

### Power light is on, but no sound is heard from some or all of the speakers

- Defective head unit or signal processor; check each component for proper wiring and operation.
- Defective GTQ amplifier; if there is audio signal present at the inputs of the amplifier and there is no output, the GTQ amplifier may be defective.

### Alternator whine through the audio system with the engine running

- Ground loops; follow the wiring suggestions in the section called "Solving Noise Problems." Also, verify that the chassis grounding point you have chosen is true ground by checking for continuity between the chassis ground point and battery ground.

### Bass output from speakers too low

- Speaker wired out of phase; check for proper polarity on all speaker wiring (+ amp terminal to + speaker terminal and - amp terminal to - speaker terminal).

### Power light is blinking and no sound is heard

- Incorrectly connected or shorted speaker wires; check for shorts in wiring.
- Defective GTQ amplifier; if there is no short on the speaker outputs, the GTQ amplifier may be broken. Consult your JBL dealer.

If you want to talk to us about any problems, call JBL Customer Service at 1-800-336-4JBL between 9AM and 5PM Eastern time.

## Solving Noise Problems

### System Noise

System noise, generally appearing as hiss, is usually the result of improper input gain (sensitivity) adjustment. With the proper setting, your JBL amplifier will not create this noise, but will amplify any noise generated ahead of it as part of the signal. Refer to "Adjusting the Gain" section on page 11 for instructions on how to minimize this noise.

### Vehicle Noise

Every vehicle has some electrical noise that is generated by the ignition system, the alternator, the accessories, and their wiring. High-performance audio equipment is more likely to pick up such noise than conventional equipment because it has wide-frequency bandwidth and high-gain (amplification) circuits. GTQ amplifiers have two built-in power supply filters to help prevent noise problems. If noise occurs it is probably the result of improper installation. The following suggestions will help you eliminate most noise problems.

**Source Noise** – Often noise in a system is picked up by the signal source. Before attempting to eliminate noise from the amp, be sure it is not being picked up by the signal source and then passed on to other components. To do this, connect the signal source output to an external amplifier which has no other connection to the vehicle except for the audio signal leads. A battery-powered amplified portable speaker, such as those sold for use with com-puters or Walkman-type

portables, works well for this. Listen to see if the noise is present in the signal from the source unit. If so, consult the manufacturer of the source unit, or your JBL dealer, for help in reducing this noise. If there is no noise in this signal, it can be eliminated as the source of your problems.

**Ground Loops** – The vast majority of noise problems are caused by inadequate or improper grounding. The head unit, the amplifier, and any other components must be grounded to a major metal member of the vehicle's frame. Make sure to choose a solid metal ground point, as some new vehicles contain structural elements made of plastic.

Most often the noise level in the system will be lower if amplifiers and signal processors that do not have isolated supplies are all grounded to the same point on the chassis. Amplifiers, such as the GTQs, which internally isolate the signal ground connection from the power ground connection, generally do not benefit from this. Usually the head unit does not need to be grounded to the same point as the rest of the system, but in some instances, depending on the design of the signal processors involved, grounding signal processors to the same point as the head unit will also help. If this does not adequately reduce the noise level, try another ground point on the car frame. Because of current flow patterns within the vehicle chassis, some ground points are noisier than others. As a general rule, try to keep grounds away from the main flow of current between

the battery and alternator. For example, in a vehicle with a battery at the right rear and an alternator at the left front, you are most likely to find a quiet ground at the far left rear than anywhere between the battery and alternator. In some rare instances with plastic-bodied vehicles, grounding the equipment directly to the battery will provide the best results, although usually this provides poor results with most cars and is not recommended. In complex systems involving components from different manufacturers, it helps to know the type of power supplies used in each component. For low-level signal processors such as equalizers or electronic crossovers, a manufacturer may use either a power supply which is isolated through a DC-to-DC converter, or a simple regulated supply from the +12V vehicle battery. The important characteristic to know is how well the power ground is isolated from the signal ground (phono-plug shield) in each component. Many simple signal processors or low-powered amplifiers have no isolation. These can be identified by a direct connection from power ground to the shield of the RCA jacks (measured with an ohmmeter with no other connections present). For these components, the best ground connection may be one where the power ground wire is not connected at all! The RCA cables will provide the ground connection to the source unit. Please note that this is only appropriate for units which draw less than 500mA of current.

Higher power units of this type, such as amplifiers, are best connected with their ground wires connected directly to the chassis of the head unit. The trickiest grounding task is created when some components of this type are mixed with other components using isolated supplies. For this type of system, the following grounding scheme will usually work:

1. Connect the head unit chassis to a solid vehicle ground using a short, heavy gauge wire (AWG10). Do not connect this to the vehicle's wiring harness, but go directly to a metal part of the vehicle.
2. Connect all signal-processor grounds directly to the head unit chassis at the same point. Run each wire individually. Due to wire resistance, connecting multiple wires to a single wire, then running the single wire to the head unit, is not the same!
3. Connect all amplifier grounds directly to the vehicle chassis but not necessarily to the same point as the head unit.

**Power-line Noise** – The built-in power supply filter of the amplifier makes external filters unnecessary. In some cases, power supply noise can enter the system through the head unit power supply or the supply of an equalizer or other signal processor. Putting a filter on the head unit or signal processor power supply input may then be helpful. Using a portable powered speaker as described in the "Source Noise" section can help you isolate an individual component which may be sensitive to this. Start at the head unit, and work back, checking each component individually.

Power wires carrying high currents may induce noise in nearby signal wires. Make sure that power wires and signal wires do not run together for long distances. When power and signal leads must cross, they should cross at right angles. If you suspect that power line noise is being induced in the signal leads, you can repeat the test for source noise described previously, but perform the test at the amplifier end of the signal cables. One power wire that will be impossible to stay away from is the vehicle chassis. The chassis is one giant ground wire! Use high-quality shielded cables, twisted pair, or a balanced-line system for the long front-to-rear signal runs to reduce the likelihood of noise pickup from this source.

**Other Noise Sources** – Common noise problems will be solved by proper grounding and power supply connections. However, there are impulse-type noise sources which may require suppression at the noise source. Many noise suppression devices (such as spark plug and coil lead suppressors, and rotor and coil bypass capacitors) are available at auto parts or car stereo stores. There are also noise suppressors that can be connected directly to the alternator that are effective in some situations. The use of any such suppressor should be discussed with a JBL authorized installation specialist after the basic grounding scheme and power connections are confirmed to be correct. Certain vehicles are particularly noisy, especially models that have solid-state ignition systems or that have non-metal

bodies. Such vehicles may require electrical noise suppression devices which are not normally needed.

**Antenna** – A common noise problem is generated by a ground loop produced by the antenna shielded cable being grounded at both the antenna mounting point and at the head unit input. In this instance, insulate the antenna ground from the chassis of the vehicle at the antenna mounting point so the antenna shield is grounded only at the radio's antenna input. Commercial antenna ground-loop isolators are also available.

**Switching Noise** – GTQ amplifiers have highly developed switching power supplies which generate some RF interference as a result of their switch-mode operation. Although this is internally filtered and shielded by the GTQ amplifier chassis, some unusually sensitive installations may pick up switching noise, especially when listening to weak AM radio stations. If this unusual situation occurs, one of the following installation corrections will typically eliminate the problem.

1. Relocate the amplifier to a position farther away from the radio or radio antenna.
2. Move the electrical ground of the head unit and/or amp to a different point on the vehicle's chassis.
3. Keep the amplifier power supply wiring away from the radio or antenna wiring.
4. Wrap the +12-volt power supply wires for the radio/tape deck and/or the GTQ amplifier with metallized shielding tape or ground braid, and ground the tape to the chassis of the vehicle.

## Specifications

### GTQ190

Power Output	30 Watts x 4 (4 Ohms, 0.05% THD)
(20Hz – 20kHz,	45 Watts x 4 (2 Ohms, 0.08% THD)
14.4V Battery Voltage)	95 Watts x 2 (Bridged 4 Ohms, 0.08% THD)
Signal-to-Noise Ratio	100dB
Frequency Response	10Hz – 50kHz (+0, –1dB) 20Hz – 20kHz (+0, – 0.1dB)
Damping Factor	> 200
Slew Factor	> 5
Line-Level Input Sensitivity (For Rated Power)	100mV – 4V RMS
Line-Level Input Impedance	10k Ohms
Speaker-Level Input Impedance	15 Ohm
Speaker-Level Input Sensitivity	200mV – 8V RMS
Preamp Output Level	
Preamp Input:	V out = V in
Speaker Input:	V out = 1/2 V in
Minimum Speaker Impedance	
Single-Ended (Non-Bridged):	2 Ohms
Bridged:	4 Ohms
Built-in Electronic Crossover Frequency and Slope	18dB per Octave Low-Pass Filter, Fixed Frequency: 80Hz  18dB per Octave High-Pass Filter, Fixed Frequency: 120Hz
Preamp Outputs	Fixed Full-Range Frequency Response: 10Hz – 50kHz (+0, –1dB)
Power Requirement	11 to 16V DC Negative Ground
Fuse Size	30 Amp ATC Type Fuse
Size (HxWxL)	2 x 8 x 10-7/8" (51 x 196 x 274mm)
Weight	10.2 lbs (4.62 kg)
Speaker-Level Input	Molex Mini-Fit Jr
Mating Connector	#39-01-2080 Metal Pins: 39-00-0038

## Maintenance

GTQ amplifiers do not require any regular maintenance. Periodically checking the main power supply and grounding points and terminal connections is advisable. Be sure the connections are solid and corrosion-free. Loose or corroded connections can cause annoying intermittent noise or unusual operational problems. Do not allow dust to accumulate on the amplifier heat sinks. It will reduce the amplifier's ability to dissipate heat. Occasional vacuum-cleaning will prevent dust accumulation.

### Declaration of Conformity



We, JBL Europe A/S  
Kongevejen 194B  
DK-3460 Birkerød  
DENMARK

declare in own responsibility, that the product described  
in this owner's manual is in compliance with technical  
standard:

EN 55 020/6.1988

Steen Michaelsen  
JBL Europe A/S  
Birkerød, DENMARK. 8/96